

# LOCK ALIGNMENT PLATE

## Installation Instructions for Marquis Single-Point Lockers Using Built-In Combination Locks

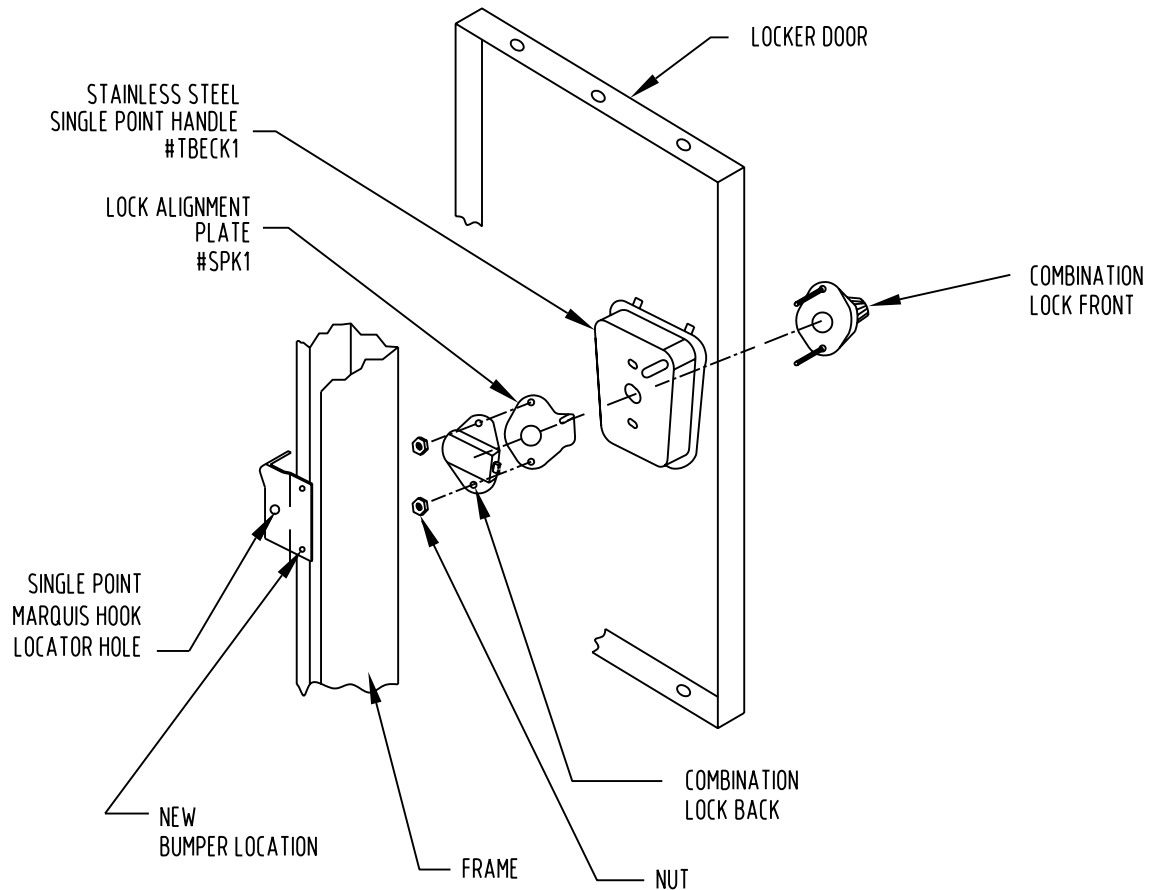

1. Remove bumper from Marquis hook and install in lower hole.
2. Insert combination lock front thru recessed handle.
3. Place the Marquis LOCK ALIGNMENT PLATE, followed by the combination lock back on the back of the recessed handle as shown.
4. Finger tighten the nuts only. This will allow the LOCK ALIGNMENT PLATE and lock to move into proper alignment with the Marquis hook..
5. Use the key to hold the lock bolt in the open position and push the door closed gently to allow the LOCK ALIGNMENT PLATE tab to locate the hole in the Marquis hook.  
  
With the tab inserted in the hook hole, the lock is now located in the optimum position.
6. When good alignment is made, tighten the nuts with a 3/8" nut driver taking care not to move the lock.

### TWO-YEAR WARRANTY

LIST INDUSTRIES K.D. LOCKERS ARE COVERED AGAINST ALL DEFECTS IN MATERIALS AND WORKMANSHIP EXCLUDING FINISH, DAMAGE RESULTING FROM DELIBERATE DESTRUCTION AND VANDALISM FOR A PERIOD OF TWO YEARS.



401 Jim Moran Blvd., P.O. Box 9601 Phone (954) 429-9155  
Deerfield Beach, FL 33442 Fax (954) 428-3843

[www.ListIndustries.com](http://www.ListIndustries.com)