

Classic KD 2-Person & Duplex Locker ASSEMBLY INSTRUCTIONS

General Instructions

1. Check material received against the packing list. Check the number of packages received and then check the contents of each package.
2. Check the material received for damage. If damage has occurred, secure a “damage notation” from the carrier
3. Identify each part as it is unpacked and put like parts together as close as possible to the working area where they are to be assembled.
4. Be careful to use the correct hardware as specified in the assembly instructions.

CAUTION

In the interest of safety, all lockers must be securely anchored to the floor and/or wall. For safety, handle all components carefully and wear work gloves when assembling lockers. Install all units plumb and tighten all hardware securely. Retain instructions for future reference.



800-776-1342
info@ListIndustries.com
www.ListIndustries.com

DUPLEX

1.

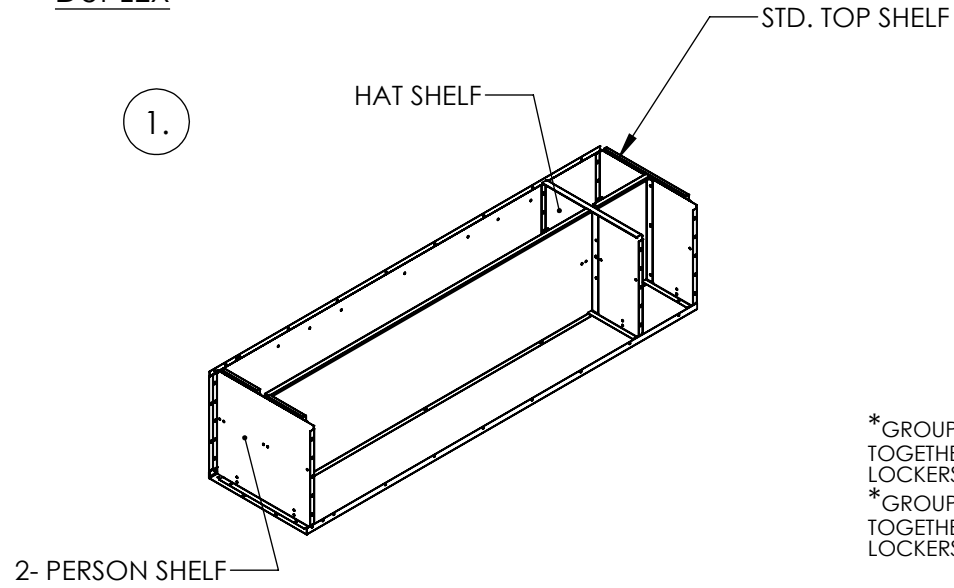

2.

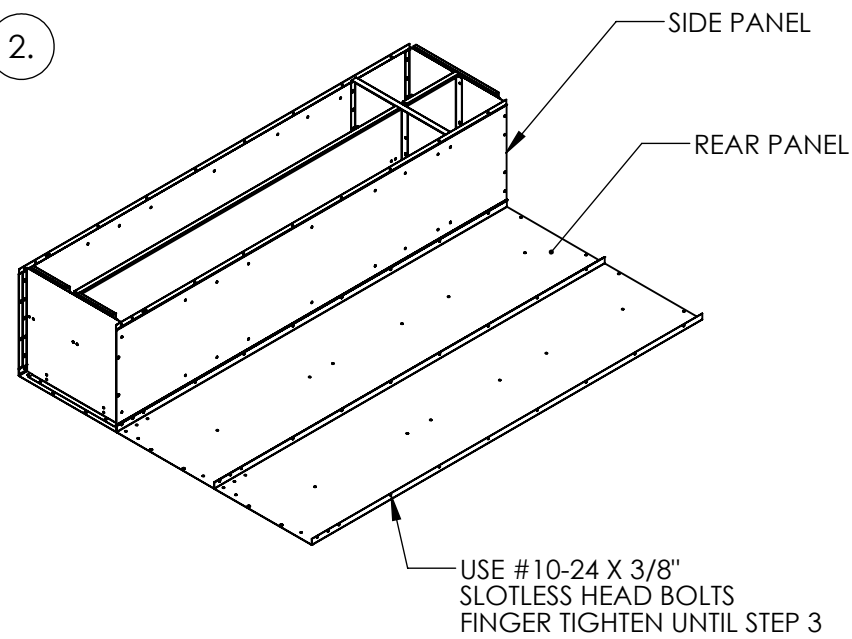

3.

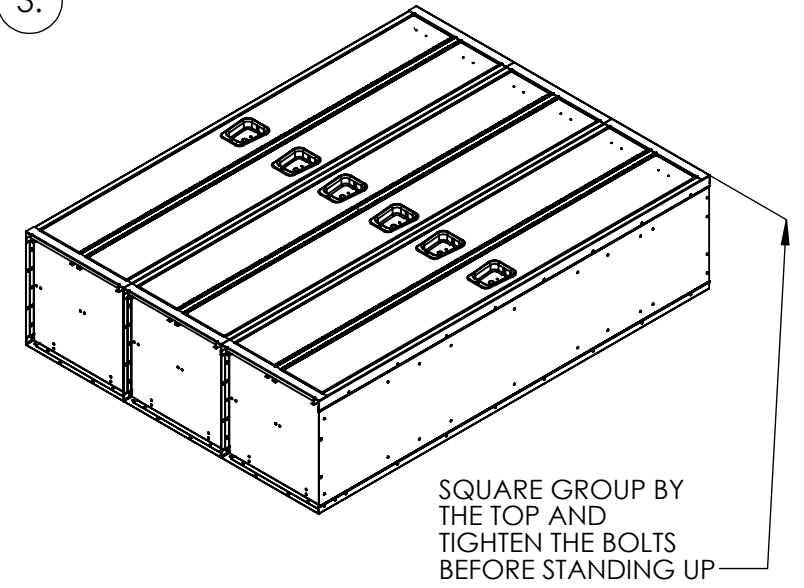

*GROUP A MAX. OF 5 UNITS TOGETHER FOR 15" LOCKERS
*GROUP A MAX. OF 4 UNITS TOGETHER FOR 18" LOCKERS

2-PERSON

1A

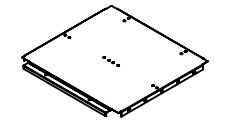
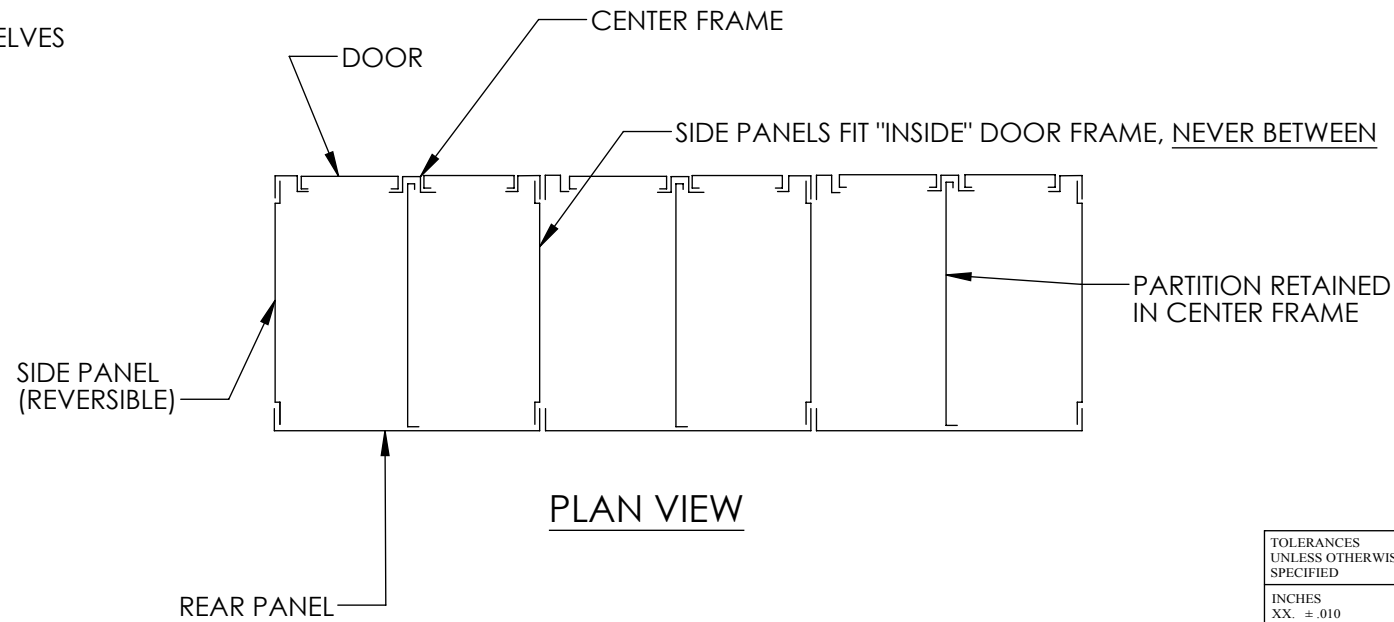
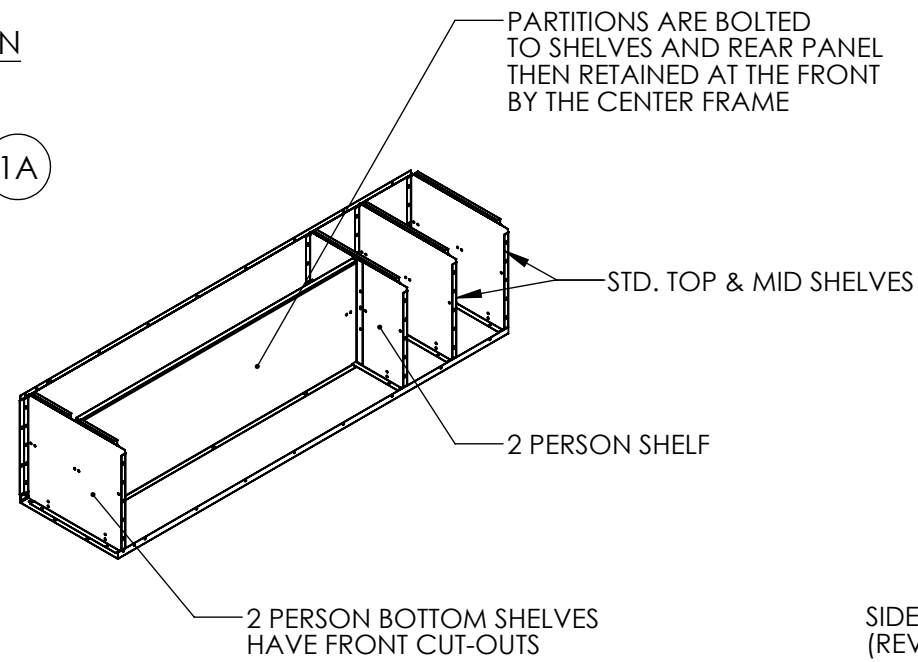

2 PERSON SHELF

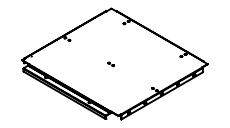

TOP AND MID

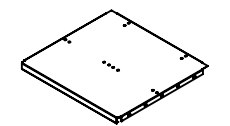

HAT SHELF

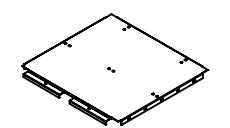

2 PERSON BOTTOM SHELF

IMPORTANT:

ALL LOCKERS SHOULD BE SECURELY ANCHORED TO WALL AND/OR FLOOR WITH SUITABLE FASTENERS

THIS DRAWING AND THE INFORMATION ON IT IS THE CONFIDENTIAL PROPERTY OF LIST INDUSTRIES INC., AND SHALL NOT BE COPIED OR DISCLOSED TO OTHERS WITHOUT WRITTEN PERMISSION. ONLY LIST INDUSTRIES INC. RESERVES THE RIGHT TO ALTER ANY DESIGN. ANY UNAUTHORIZED MODIFICATIONS RELEASES LIST INDUSTRIES INC. FROM ALL LIABILITIES.

| | | | | | | |
|--|--|---|--|---|-------------|------|
| TOLERANCES UNLESS OTHERWISE SPECIFIED | |  www.ListIndustries.com 401 Jim Moran Blvd., PO Box 9601 Deerfield Beach, FL 33442 Tel (954) 429-9155 Fax (954) 428-3843 | | | | |
| INCHES XX. ± .010 XXX. ± .005 | | | | | | |
| FRACTIONAL X/X. ± 1/64 | | DRAWN BY: JIL CHECKED BY: APPROVED BY: | DATE: 9/29/2010 DATE: DATE: | DESCRIPTION: ASSEMBLY INTRUCTIONS DUPLEX & 2 PERSON LOCKERS | | |
| ANGULAR ∠ ± 1/2° | | SCALE | SHEET | PART NO. | DRAWING NO. | REV. |
| UNLESS OTHERWISE SPECIFIED ALL DIMENSIONS ARE IN INCHES. METRIC DIMENSIONS WILL BE WITHIN [XX] | | 1 OF 1 | | | SA0160 | |