

CUBIX™ MODULAR LOCKER ASSEMBLY INSTRUCTIONS

General Instructions

1. Check material received against the packing list. Check the number of packages received and then check the contents of each package.
2. Check the material received for damage. If damage has occurred, secure a “damage notation” from the carrier
3. Identify each part as it is unpacked and put like parts together as close as possible to the working area where they are to be assembled.
4. Be careful to use the correct hardware as specified in the assembly instructions.

CAUTION

In the interest of safety, all lockers must be securely anchored to the floor and/or wall. For safety, handle all components carefully and wear work gloves when assembling lockers. Install all units plumb and tighten all hardware securely. Retain instructions for future reference.



800-776-1342
info@ListIndustries.com
www.ListIndustries.com

ITEM NO.	PART NUMBER	DESCRIPTION	QTY.
1	HCFS1212/18	TOP/BOTTOM	2
2	HCSP1212/18	SIDE PANEL	2
3	HCLF12-1FP	LATCH FRAME	1
4	KBLP100	DOOR PULL	1
5	LKD1272-6DP/PL/SVP	DOOR	1
6	HCHF12-1	HINGE FRAME	1
7	HCBP1212	BACK PANEL	1
8	KBLH101P	LATCH	1
9	NPH100	NUMBER PLATE	1
10	MBT200	BOLT	20
11	N201	NUT	18
12	N110	DOME NUT	2
13	RV101P	PLASTIC RIVET	2
14	TCS100	SCREW	3

REVISIONS			
REV.	DESCRIPTION	DATE	BY
A	RV101P WAS MBT400 & N104	3/24/2017	ROW

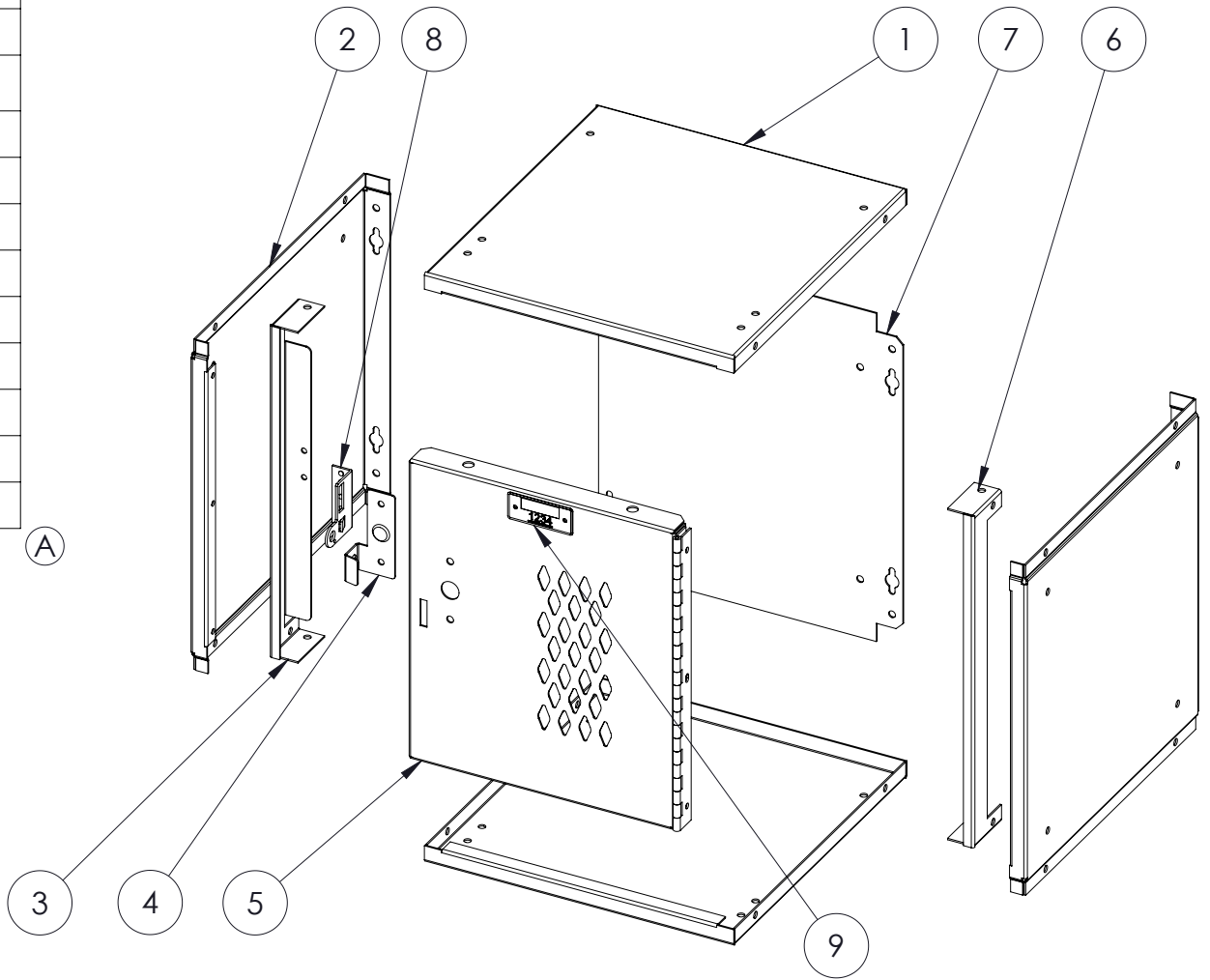

10



11



12

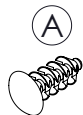

13



14

TOLERANCES
UNLESS OTHERWISE
SPECIFIED

INCHES
XX. ± .010
XXX. ± .005

FRACTIONAL
X/X. ± 1/64

ANGULAR
∠ ± 1/2°

UNLESS OTHERWISE
SPECIFIED ALL
DIMENSIONS ARE IN
INCHES. METRIC
DIMENSIONS WILL BE
WITHIN [XX]

DRAWN BY	DATE	DESCRIPTION	SCALE	SHEET	PART NO.	DRAWING NO.	REV.
JIL	1/16/2013	CUBIX LOCKER HC12(12/18)12	1 OF 1	1 OF 1		SA1566	A
CHECKED BY	DATE						
APPROVED BY	DATE						
RAM	3/24/17						

STEP 1

Note: Bolts and nuts should only be finger tight throughout the assembly process.

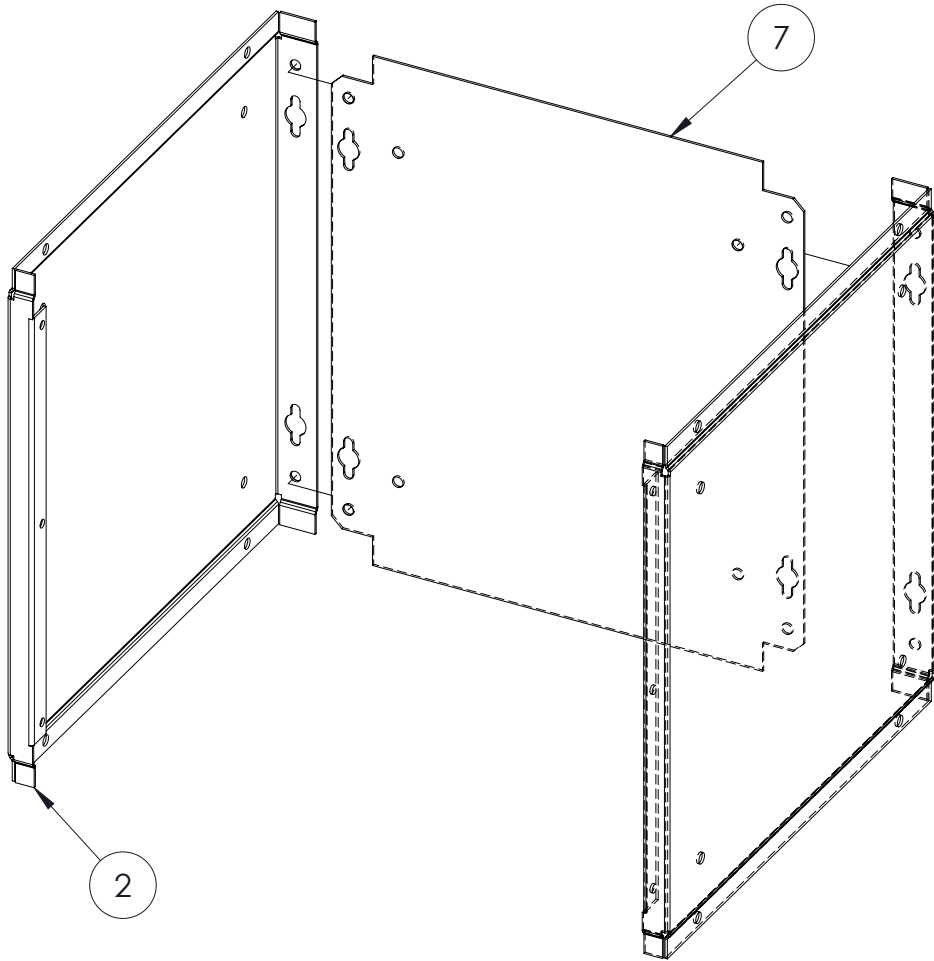

-Bolt side panels (HCSP1212) and back (HCBP1212) together. Back is bolted to the inside of the unit.



11



10

HARDWARE NEEDED

STEP 2

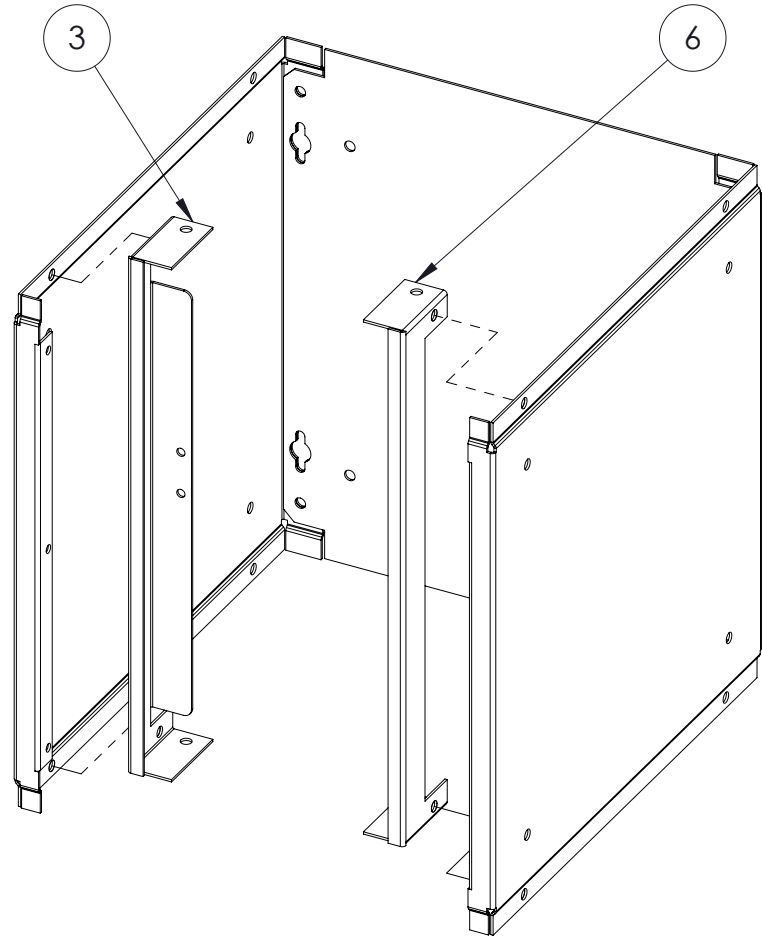

-Insert left (HCLF12-1FP) frame and right (HCHF12-1) frame into the inside flanges of the side panel. Do not bolt yet!

STEP 3

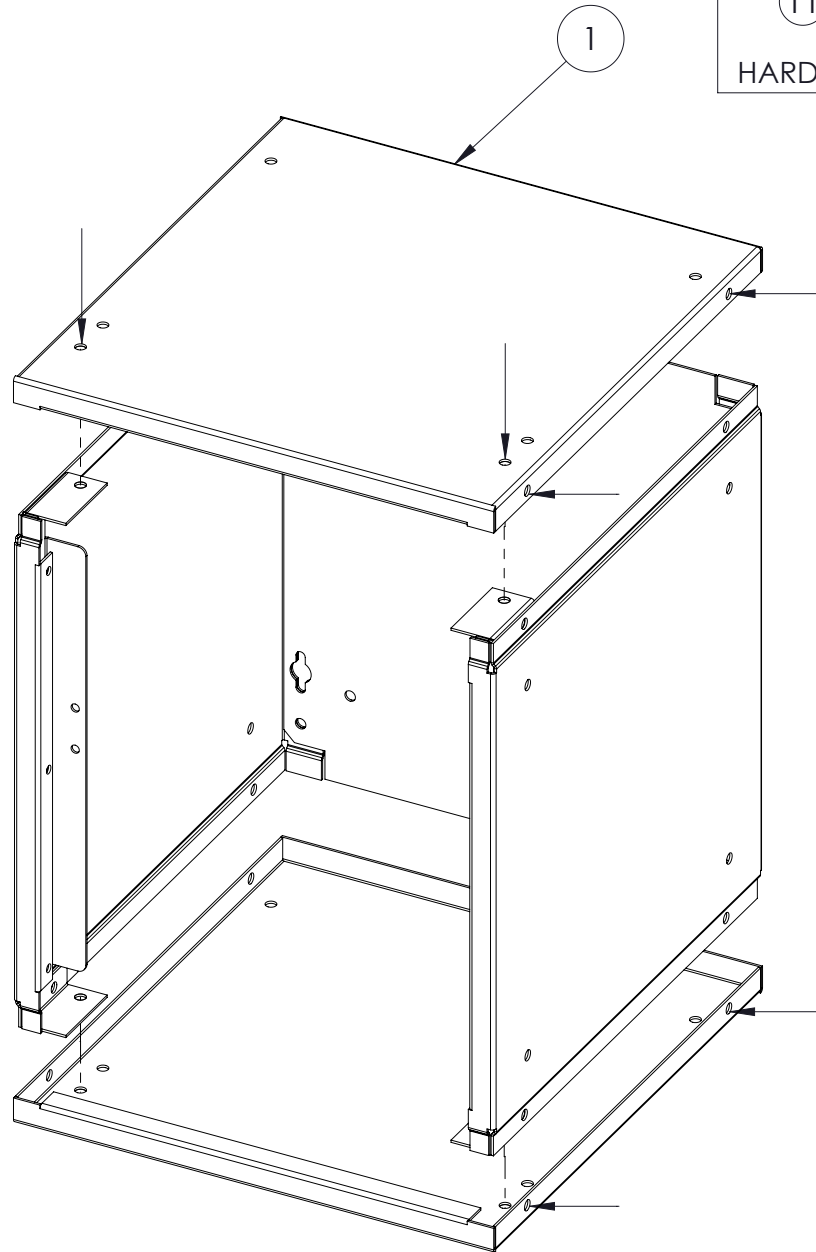

11

10

HARDWARE NEEDED

STEP 4

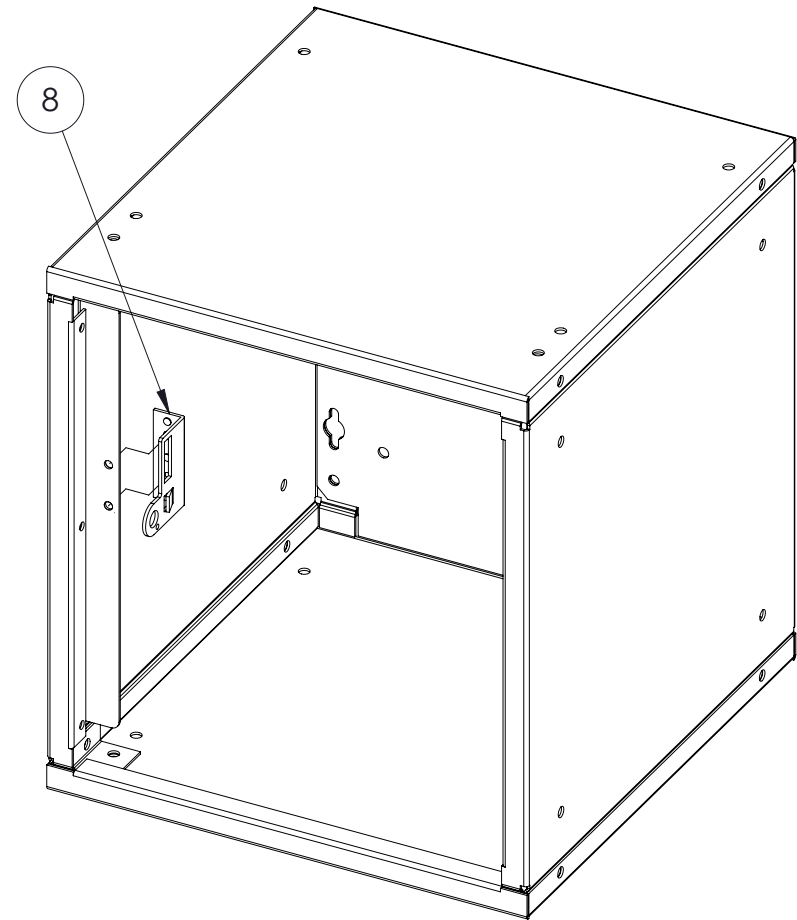

-Place top/bottom (HCFS1212) and bolt the side panels and frames to it.

-Bolt the latch (KBLH101) to the latch frame.

STEP 5

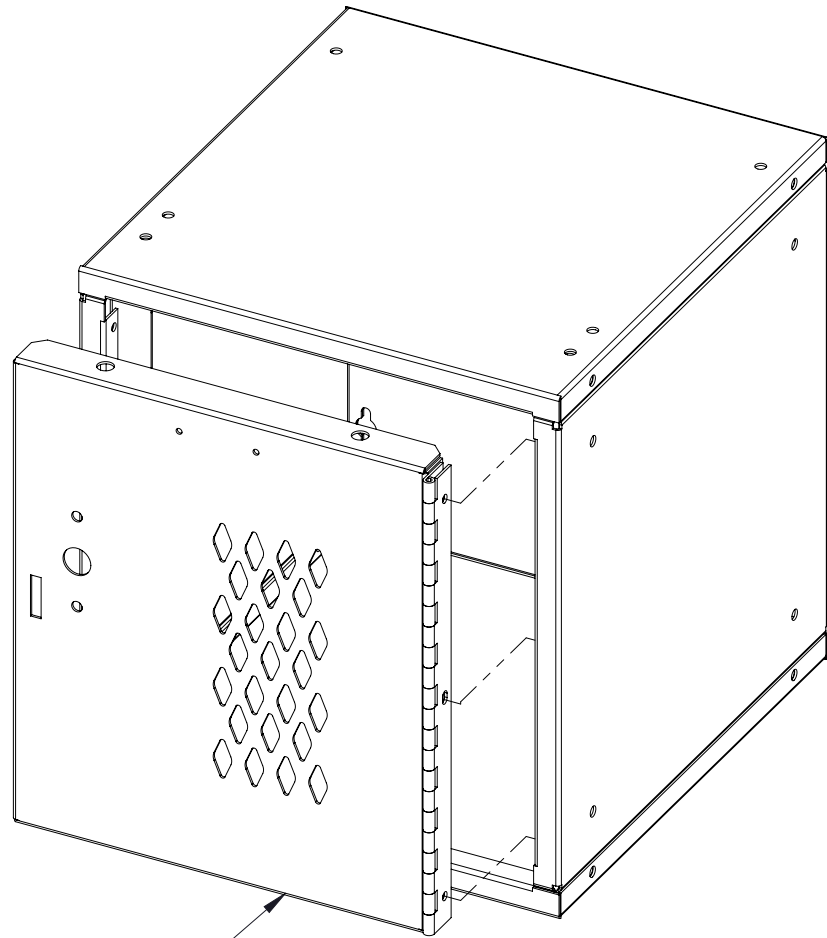

5



14

HARWARE NEEDED

STEP 6

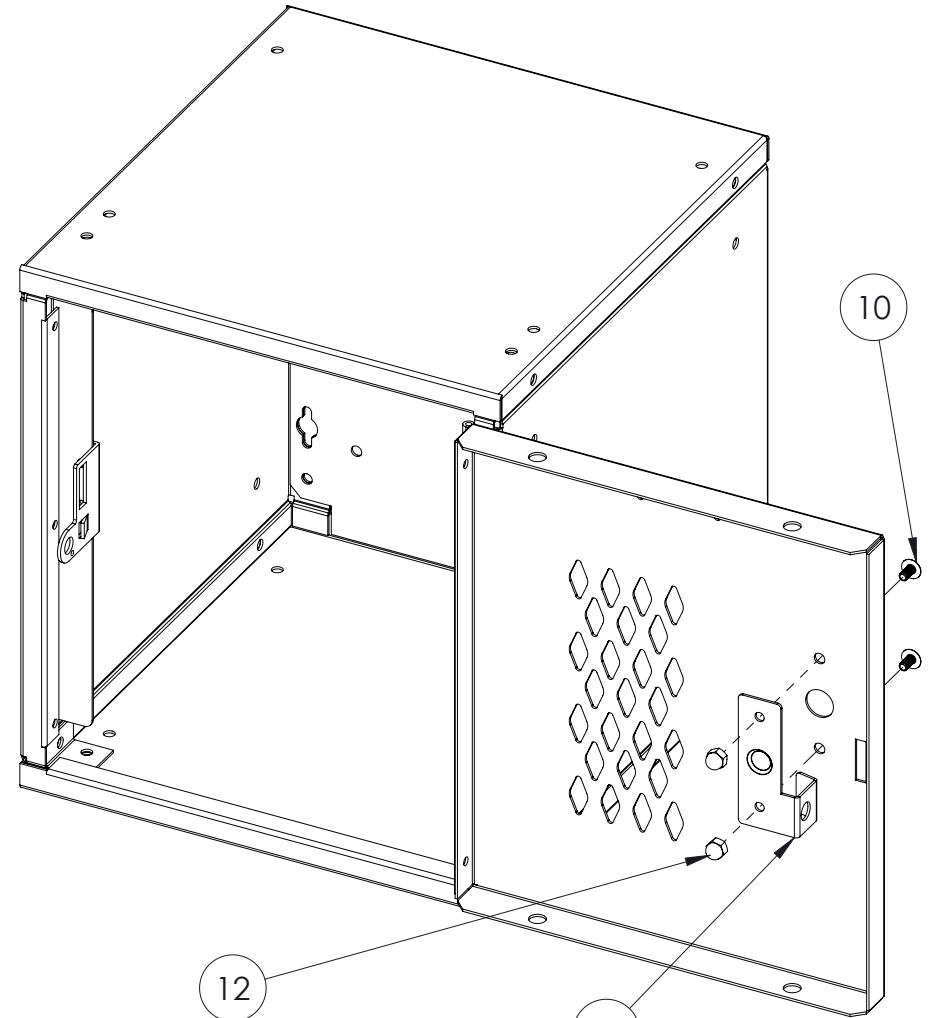

10

12

4

-Attach finger pull to door using (N110) nuts and (MBT200) bolts.

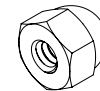

12

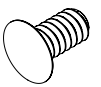

10

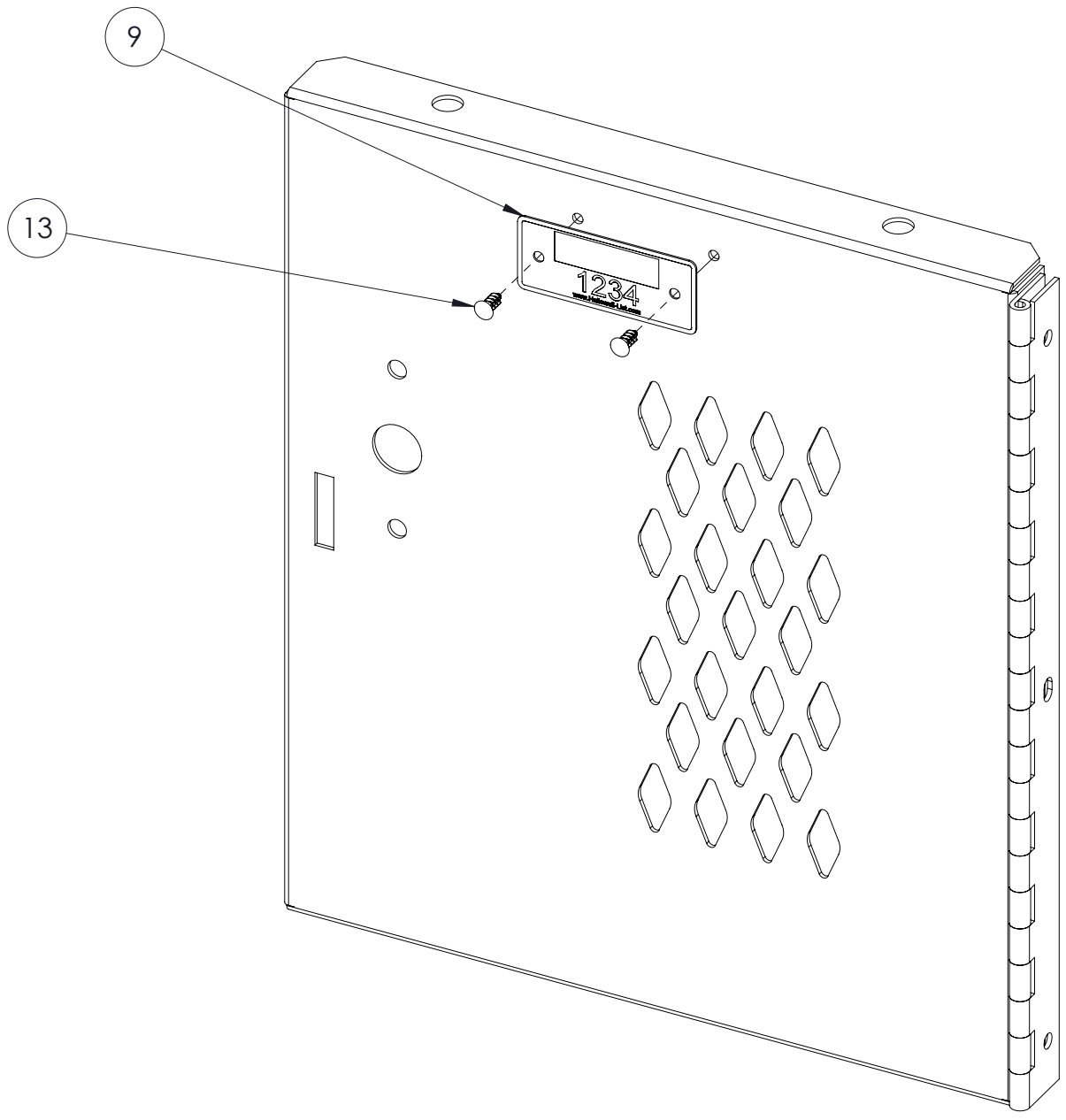

13

HARWARE