

# SAFETY-VIEW PLUS K. D. 16-PERSON STOCK LOCKER ASSEMBLY INSTRUCTIONS

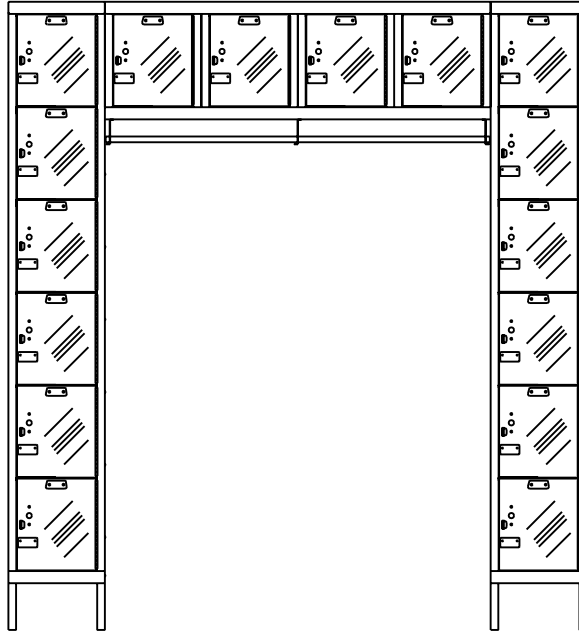

## General Instructions

1. Check material received against the packing list. First check the number of packages received and then check the contents of each package.
2. Check material received for damage. If damage has occurred, secure a "damage notation" from the carrier.
3. Identify each part as it is unpacked and put like parts together as close as possible to the working area in which they are to be assembled.
4. Be careful to use the correct hardware as specified in the assembly instructions.
5. Items with suffix (xx) are available options.

## CAUTION

IN THE INTEREST OF SAFETY, ALL LOCKERS MUST BE SECURELY ANCHORED TO THE FLOOR AND/OR WALL.  
FOR SAFETY, HANDLE ALL COMPONENTS CAREFULLY AND WEAR WORK-GLOVES WHEN ASSEMBLING LOCKERS.

INSTALL ALL UNITS PLUMB AND TIGHTEN ALL HARDWARE SECURELY.

RETAIN INSTRUCTIONS FOR FUTURE REFERENCE.



401 Jim Moran Blvd., P.O. Box 9601  
Deerfield Beach, FL 33442

Phone (954) 429-9155  
Fax (954) 428-3843

[www.ListIndustries.com](http://www.ListIndustries.com)

# SAFETY-VIEW PLUS K. D. 16-PERSON STOCK LOCKER ASSEMBLY INSTRUCTIONS

## PACKAGE CONTENTS

REF. NO	DESCRIPTION	PART NO.	QTY.
①	REAR PANEL	KR1272	2
②	RIGHT/LEFT SIDE PANEL	KP1872-16P	4
③	TOP/BOTTOM SHELF	KS1218	4
④	INTERMEDIATE SHELF	KH1218	10
⑤	DOOR FRAME ASSEMBLY	LKDF1278-6SVP	2
x ⑥	DOOR	LKD1272-6SVP	16
⑦	BOX DOOR LATCH PULL	KBLP100	16
⑧	NUMBER PLATE	NPL	16
⑨	NUMBER PLATE RIVET	RV101	32
xx ⑩	STRIKE PLATE	xxSP100	xx16
⑪	REAR LEG	KLK	4
⑫	3/8" SLOTLESS BOLT	MBT200	243
⑬	HEX NUT	N201	211
⑭	HI-DOME CAP NUT	N110	32
x ⑮	PIANO HINGE	PH11	16
⑯	COAT ROD BRACKET	TRH 200	3
⑰	COAT ROD	KCR48	1
⑱	DOOR FRAME ASSEMBLY	LKDF4812-16SVP	1
⑲	CENTER REAR PANEL	KR16CP	1
⑳	CENTER BOTTOM	KP16CB18	1
㉑	CENTER TOP	KP16CT18	1
㉒	CENTER SIDE PANEL	KP16CS18	3
x ㉓	RIVET (HINGE)	RV102	32

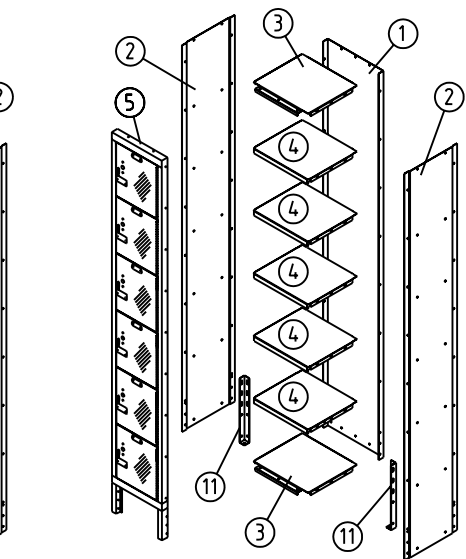
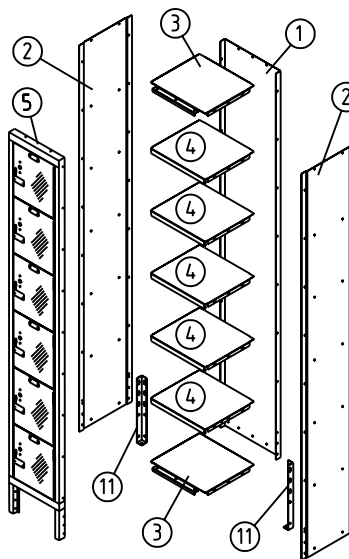
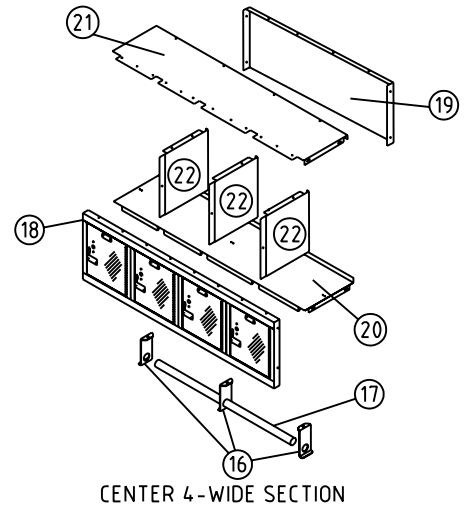
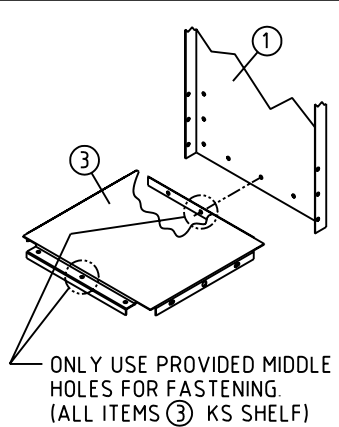

### NOTE:

FOR OPTIONAL INDIVIDUAL SLOPE TOPS,  
SEE SUPPLEMENTAL INSTRUCTION SHEET NO. ASY-L-KIST-A

FOR OPTIONAL 6" HIGH CLOSED METAL BASE,  
SEE SUPPLEMENTAL INSTRUCTION SHEET NO. ASY-L-KIST-B

x SHIPS PRE-HUNG IN FRAME ASSEMBLY.

xx STRIKE PLATES ARE OPTIONAL - INCLUDES TWO RIVETS ⑨.

**TOOLS REQUIRED: 3/8" NUT  
DRIVER (3/8" SOCKET MAY BE  
SUBSTITUTED)**

### TWO-YEAR WARRANTY

LIST INDUSTRIES KD LOCKERS ARE COVERED AGAINST ALL DEFECTS IN MATERIALS AND WORKMANSHIP EXCLUDING FINISH, DAMAGE RESULTING FROM DELIBERATE DESTRUCTION AND VANDALISM FOR A PERIOD OF TWO YEARS.



# SAFETY-VIEW PLUS K.D. 16-PERSON STOCK LOCKER ASSEMBLY INSTRUCTIONS

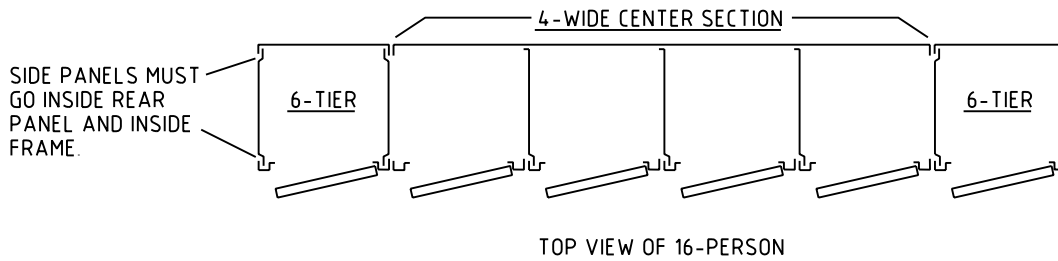

## 6-TIER LEFT AND RIGHT TOWER SECTIONS FINGER TIGHTEN ONLY UNTIL FINAL ASSEMBLY

### STEP 1

LAY REAR KR ① DOWN

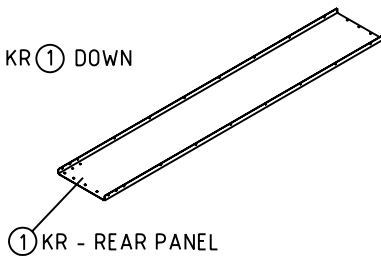

### STEP 2

BOLT KP ② SIDE PANELS TO KR ① REAR PANELS.

SIDE PANELS ② NEVER FIT BETWEEN KR ① REAR PANEL FLANGES.

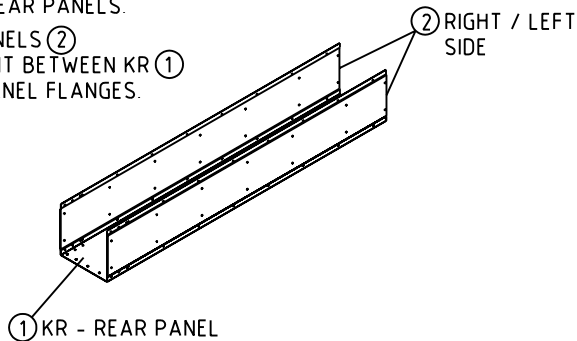

### STEP 3

INSTALL KS ③ SHELVES AND KH ④ SHELVES TO UNIT.

NOTE: LEAVE TOP SHELF ③ AND TOP HAT SHELF ④ OF 6-TIER UNFASTENED AS SHOWN UNTIL CENTER SECTION FRAME IS BOLTED IN PLACE.

INSTALL TWO KLG ⑪ REAR LEGS TO INSIDE OF SIDE ② AND REAR PANEL ① BY SLIDING INTO PLACE FROM BOTTOM.

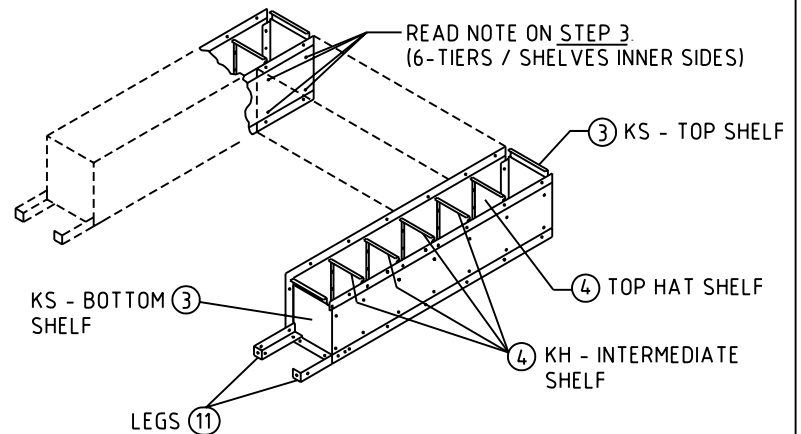

### STEP 4

BOLT DOOR AND FRAME ⑤ ASSEMBLIES TO KS ③ SHELVES AND KP ② SIDE PANELS. STAND UNIT UP AND ALIGN LOCKER TOPS EVENLY. TIGHTEN ALL BOLTS AND NUTS.

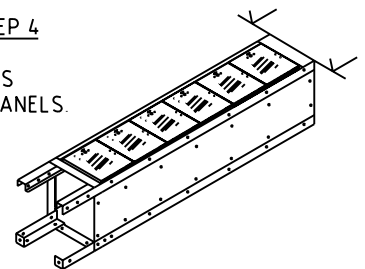

LIST INDUSTRIES MAKES EVERY EFFORT TO ENSURE THAT ALL UNITS SHIP COMPLETE. HOWEVER, SHOULD YOUR UNIT CONTAIN MISSING OR DAMAGED PARTS, REPLACEMENTS MAY BE OBTAINED FROM LIST INDUSTRIES. TO OBTAIN PARTS, FOLLOW THESE INSTRUCTIONS.

PLEASE PROVIDE THE FOLLOW INFORMATION:

MODEL NUMBER

PURCHASE DATE

DESCRIPTION OF PART(S) NEEDED & PART NUMBER(S) AS SHOWN IN PARTS LIST

COMPANY NAME & CONTACT PERSON

COLOR

WHERE THE PRODUCT WAS PURCHASED FROM

IF REQUESTING PARTS BY TELEPHONE, ASK FOR CUSTOMER SERVICE & PROVIDE THE ABOVE INFORMATION.



# SAFETY-VIEW PLUS K.D. 16-PERSON STOCK LOCKER ASSEMBLY INSTRUCTIONS

## CENTER SECTION

### STEP 5

BOLT KP16CT (21) CENTER TOP TO KP16CS (22) CENTER PANEL.

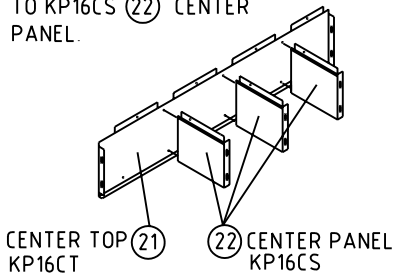

### STEP 6

BOLT (21) TOP AND (22) CENTER PANEL TO KR16CP (19) CENTER REAR PANEL.

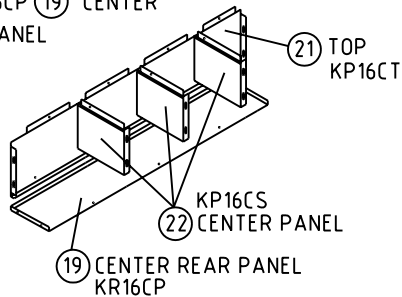

### STEP 7

BOLT KP16CB (20) CENTER BOTTOM TO (19) CENTER REAR AND (22) CENTER PANEL.

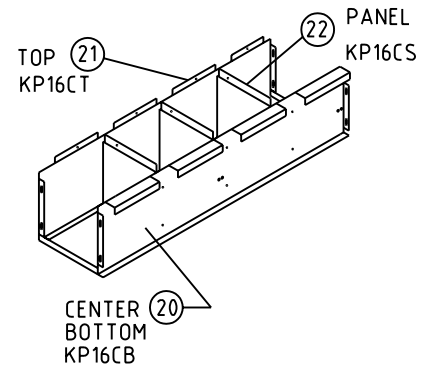

### STEP 8

BOLT KF4812-16A (18) DOOR FRAME ASSEMBLY TO CENTER ASSEMBLY.

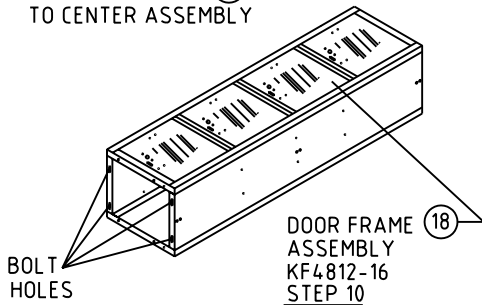

### STEP 9

WITH REAR OF CENTER SECTION ON A FLAT SURFACE, ATTACH TO LEFT AND RIGHT 6-TIER LOCKERS, TOP SHELVES AND TOP HAT SHELVES INNER SIDES, USING 10-24 x 1/2" BOLTS THRU HOLES SHOWN ON STEP 3 AND STEP 8.

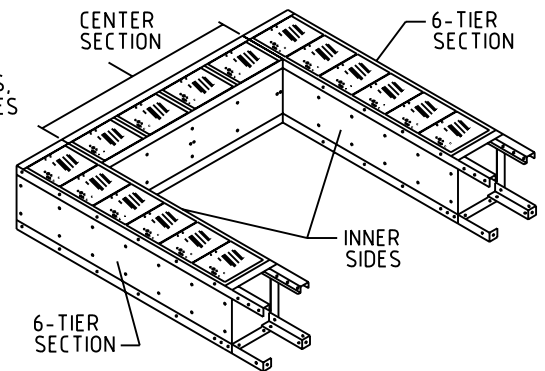

### STEP 11

BRACKETS TO BE BOLTED TO UNDER SIDE OF CENTER UNIT WITH COAT ROD IN BETWEEN.

- (16) COAT ROD BRACKET TRH 200
- (17) COAT ROD KCR48

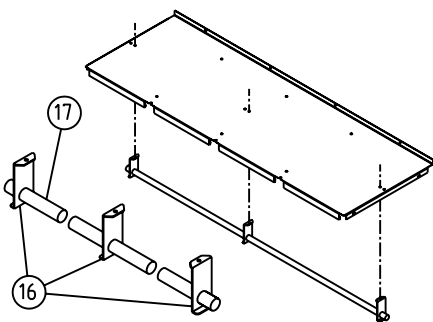

STAND LOCKER SECTION

### STEP 12

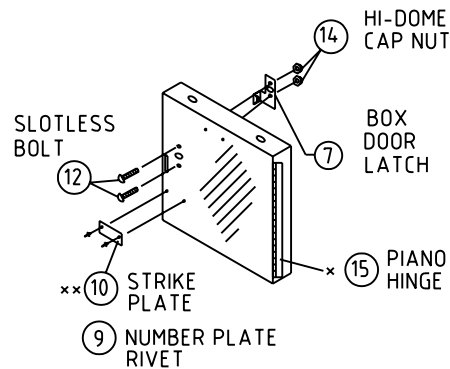

ASSEMBLY OF STRIKE PLATE & LATCH PULL

### STEP 13

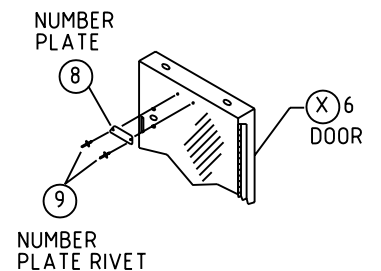

ASSEMBLY OF NUMBER PLATE

### HARDWARE USED FOR MAIN LOCKER ASSEMBLY



10 - 24 x 3/8"



N201 HEX NUT (13)

MBT200 SLOTLESS BOLT (12)

TIGHTEN NUT WITH A NUT DRIVER OR WRENCH (SCREW IS TAMPER RESISTANT).

