

HEAVY-DUTY VENTILATED K.D. STOCK LOCKER ASSEMBLY INSTRUCTIONS

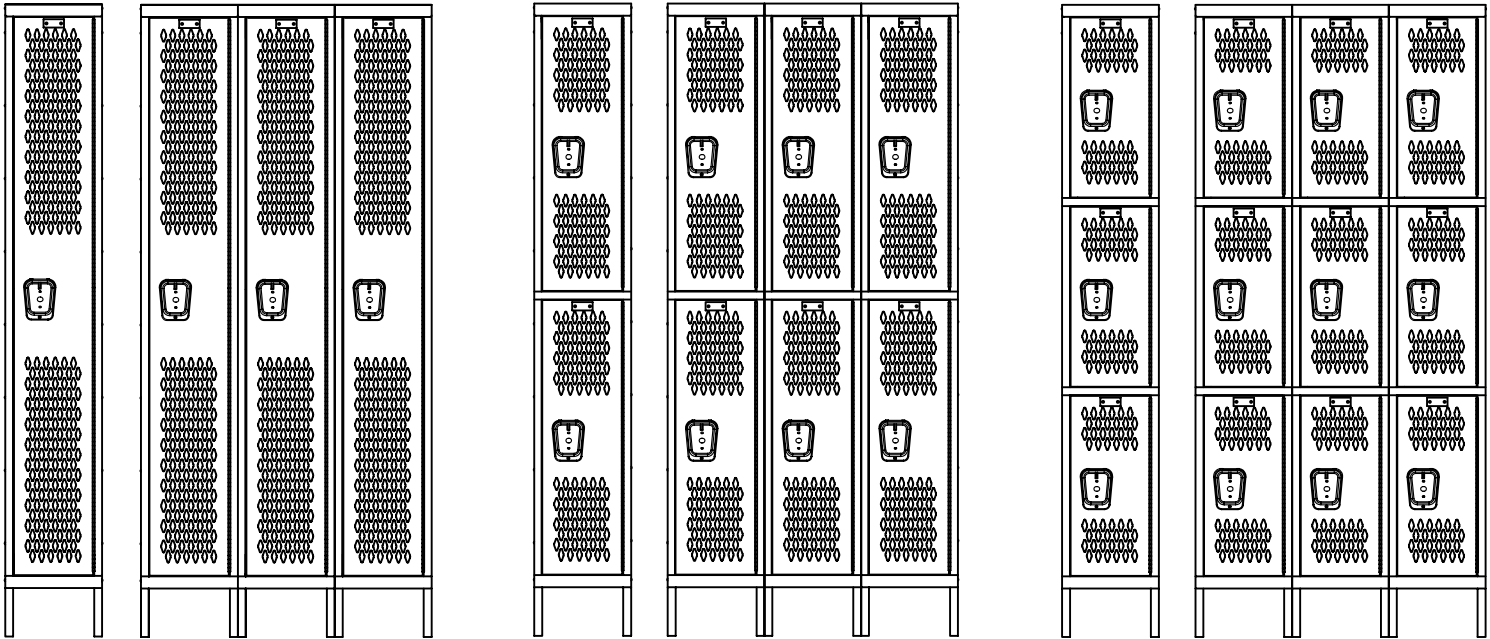

1 WIDE

3 WIDE

SINGLE TIER

1 WIDE

3 WIDE

DOUBLE TIER

1 WIDE

3 WIDE

TRIPLE TIER

General Instructions

1. Check material received against the packing list. First check the number of packages received and then check the contents of each package.
2. Check material received for damage. If damage has occurred, secure a "damage notation" from the carrier.
3. Identify each part as it is unpacked and put like parts together as close as possible to the working area in which they are to be assembled.
4. Be careful to use the correct hardware as specified in the assembly instructions.
5. Items with suffix (xx) are available options.

CAUTION

IN THE INTEREST OF SAFETY, ALL LOCKERS MUST BE SECURELY ANCHORED TO THE FLOOR AND/OR WALL.
FOR SAFETY, HANDLE ALL COMPONENTS CAREFULLY AND WEAR WORK-GLOVES WHEN ASSEMBLING LOCKERS.

INSTALL ALL UNITS PLUMB AND TIGHTEN ALL HARDWARE SECURELY.

RETAIN INSTRUCTIONS FOR FUTURE REFERENCE.



401 Jim Moran Blvd., P.O. Box 9601
Deerfield Beach, FL 33442

Phone (954) 429-9155
Fax (954) 428-3843

www.ListIndustries.com

HEAVY-DUTY VENTILATED K.D. STOCK LOCKER ASSEMBLY INSTRUCTIONS

PACKAGE CONTENTS

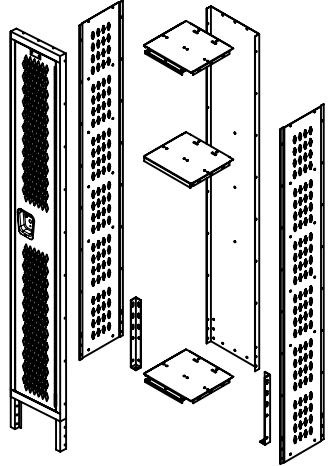
REF. NO.	DESCRIPTION	PART NO.	1-WIDE QUANTITY			3-WIDE QUANTITY			
			1-TIER	2-TIER	3-TIER	1-TIER	2-TIER	3-TIER	
①	REAR PANEL	KRwwhh-18	1	1	1	3	3	3	 <p style="text-align: center;">Single Tier KD Locker</p> <p>PART NUMBER SUFFIX SHOWS WIDTH, DEPTH, HEIGHT AND TIER. CUSTOMER TO SPECIFY.</p>
②	RIGHT/LEFT SIDE PANEL	KPddhh-DP16	2	2	2	4	4	4	
③	TOP/BOTTOM SHELF	KSwwdd-16	2	3	4	6	9	12	
④	HAT SHELF	KHwwdd-16	1	-	-	3	-	-	
⑤	SINGLE CEILING HOOK	H5K	2	4	-	6	12	-	
⑥	DOUBLE CEILING HOOK	H7K	1	2	3	3	6	9	
xx⑦	COAT ROD BRACKET	xxTHR200	xx2	xx4	-	xx6	xx12	-	
xx⑧	COAT ROD	xxKCRww	xx1	xx2	-	xx3	xx6	-	
⑨	DOOR FRAME ASSEMBLY	KDFww78-tHV	1	1	1	3	3	3	
x⑩	DOOR	KDww72-tDP14	1	2	3	3	6	9	
x⑪	RECESSED HANDLE S.S.	TBECK2	1	2	3	3	6	9	
x⑫	LOCK CHANNEL	KLhh-t	1	2	3	3	6	9	
x⑬	CHANNEL STOP	CS002	2	4	6	6	12	18	
x⑭	NYLON LATCH	DLB100B	2	4	6	9	12	18	
x⑮	SPRING	LS100	2	4	6	9	12	18	
x⑯	LOCK BRACKET	SLB101L	1	2	3	3	6	9	
x⑰	PLASTIC LIFTER	LC100B	1	2	3	3	6	9	
⑱	REAR LEG	KLG	2	2	2	2	2	2	
x⑲	BUMPER	KDB300	3	4	6	9	12	18	
⑳	NUMBER PLATE	NPL	1	2	3	3	6	9	
㉑	NUMBER PLATE RIVET	RV101	2	4	6	6	12	18	
㉒	1/2" SLOTLESS BOLT	MBT202	62	74	70	134	166	188	
㉓	HEX NUT	N201	60	70	64	128	154	170	
㉔	ESCUTCHEON PLATE	RPE100	1	2	3	3	6	9	
㉕	HI-DOME CAP NUT	N110	2	4	6	6	12	18	
x㉖	RIVET (HANDLE)	RV102	1	2	3	3	6	9	
x㉗	RIVET (HINGE)	RV102	7	8	9	21	24	27	

NOTE:

FOR OPTIONAL INDIVIDUAL SLOPE TOPS,
SEE SUPPLEMENTAL INSTRUCTION SHEET NO. ASY-L-KIST-A

FOR OPTIONAL 6" HIGH CLOSED METAL BASE,
SEE SUPPLEMENTAL INSTRUCTION SHEET NO. ASY-L-KIST-B

x SHIPS PRE-HUNG IN DOOR FRAME ASSEMBLY ⑨

xx OPTIONAL ITEM

PART NO. LEGEND:

ww = WIDTH
dd = DEPTH
hh = HEIGHT (FRAME)
t = TIER
V = VENTILATED

**TOOLS REQUIRED: 3/8" NUT
DRIVER (3/8" SOCKET MAY BE
SUBSTITUTED)**

TWO-YEAR WARRANTY

LIST INDUSTRIES K.D. LOCKERS ARE COVERED AGAINST ALL DEFECTS IN MATERIALS AND WORKMANSHIP EXCLUDING FINISH, DAMAGE RESULTING FROM DELIBERATE DESTRUCTION AND VANDALISM FOR A PERIOD OF TWO YEARS.



HEAVY-DUTY VENTILATED K.D. STOCK LOCKER ASSEMBLY INSTRUCTIONS

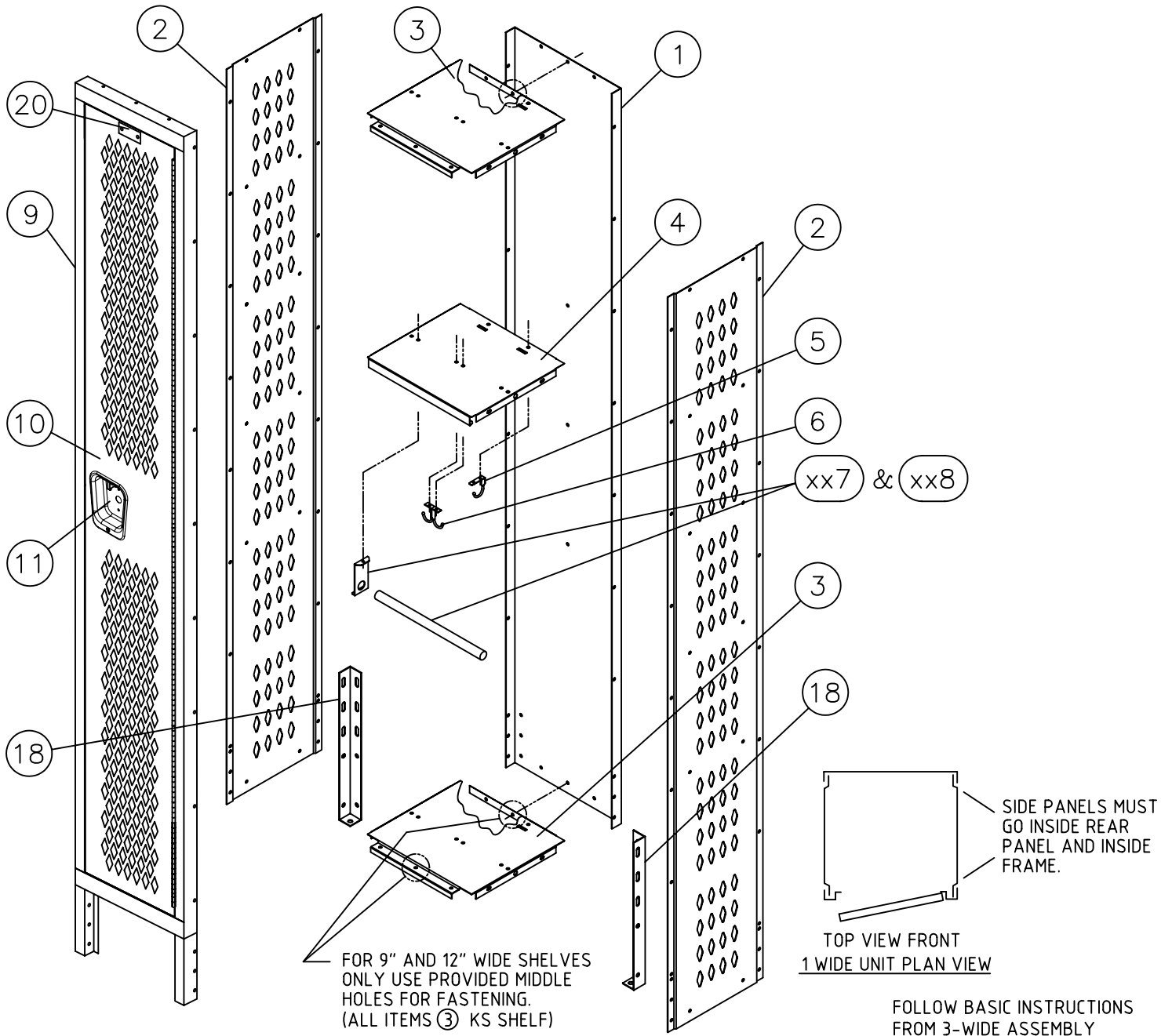

COAT ROD (KCR_{ww}) & COAT ROD BRACKETS (TRH 200) ARE OPTIONAL.

LIST INDUSTRIES MAKES EVERY EFFORT TO ENSURE THAT ALL UNITS SHIP COMPLETE; HOWEVER, SHOULD YOUR UNIT CONTAIN MISSING OR PARTS, REPLACEMENTS MAY BE OBTAINED FROM LIST INDUSTRIES. TO OBTAIN PARTS, FOLLOW THESE INSTRUCTIONS.

PLEASE PROVIDE THE FOLLOW INFORMATION:

MODEL NUMBER

PURCHASE DATE

DESCRIPTION OF PART(S) NEEDED & PART
NUMBER(S) AS SHOWN IN PARTS LIST

COMPANY NAME & CONTACT PERSON

COLOR

WHERE THE PRODUCT WAS PURCHASED FROM

IF REQUESTING PARTS BY TELEPHONE, ASK FOR CUSTOMER SERVICE & PROVIDE THE ABOVE INFORMATION.



HEAVY-DUTY VENTILATED K. D. STOCK LOCKER

ASSEMBLY INSTRUCTIONS

(A GROUPING OF 3-WIDE SINGLE TIER LOCKERS ILLUSTRATED)

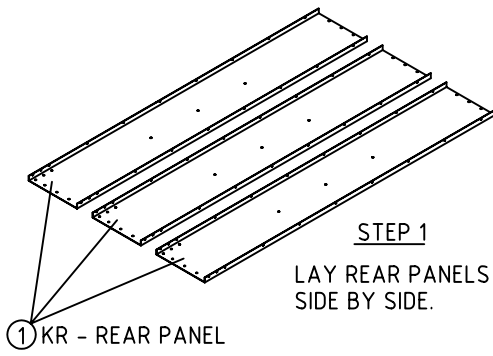

STEP 1
LAY REAR PANELS
SIDE BY SIDE.

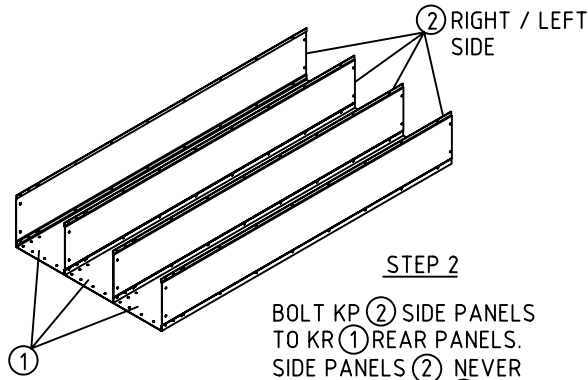

STEP 2
BOLT KP ② SIDE PANELS
TO KR ① REAR PANELS.
SIDE PANELS ② NEVER
FIT BETWEEN KR ① REAR
PANEL FLANGES.

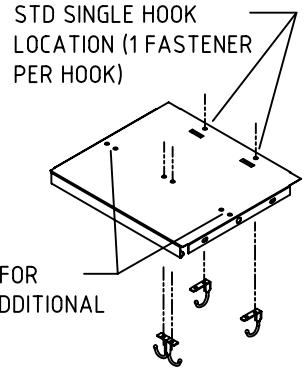

STD SINGLE HOOK
LOCATION (1 FASTENER
PER HOOK)

STEP 3
INSTALL DOUBLE CEILING
HOOK (H7K) ⑥ AND SINGLE
CEILING HOOKS (H5K) ⑤
TO (KH) ④ HAT SHELF.

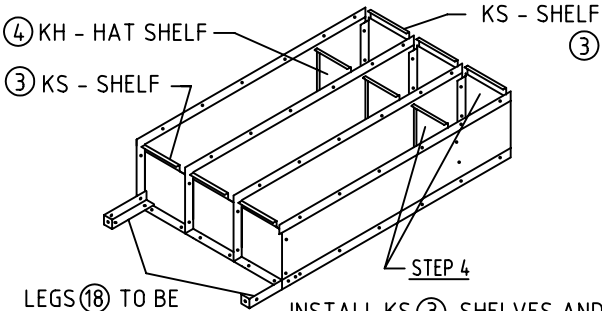

LEGS ⑱ TO BE
AT 36" INTERVALS

STEP 4
INSTALL KS ③ SHELVES AND
KH ④ SHELVES TO UNIT.
INSTALL TWO KLG ⑱ REAR
LEGS TO INSIDE OF SIDE ②
AND REAR
PANEL ① BY SLIDING INTO PLACE FROM BOTTOM.

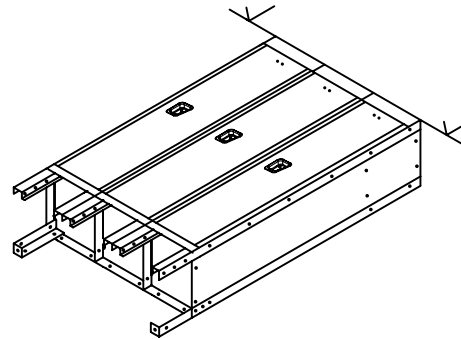

STEP 5
BOLT DOOR AND FRAME ⑨ ASSEMBLIES
TO KS ③ SHELVES AND KP ② SIDE
PANELS. STAND UNIT UP AND ALIGN
LOCKER TOPS EVENLY. TIGHTEN ALL
BOLTS AND NUTS.
NOTE: WHEN BOLTING ONE UNIT TO
ANOTHER, OMIT ONE SET OF BOLTS
IN END FRAME AND SIDE TO MINIMIZE
GROWTH FROM BOLT HEADS.

ASSEMBLY OF SINGLE ROW LOCKERS
NEVER PUT SIDE PANELS BETWEEN
FRAMES OR REAR PANELS.

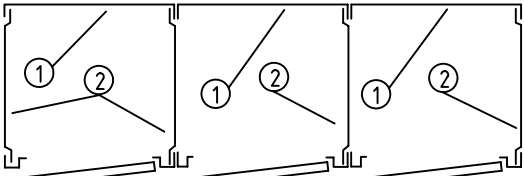

SINGLE TIER EXAMPLE - 3 WIDE UNIT PLAN VIEW

SIDE PANELS MUST
GO INSIDE REAR
PANEL AND INSIDE
FRAME.

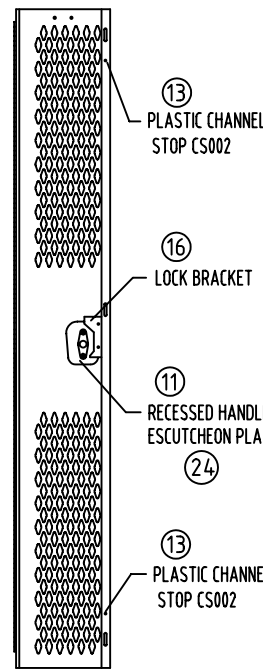

INSIDE DOOR VIEW

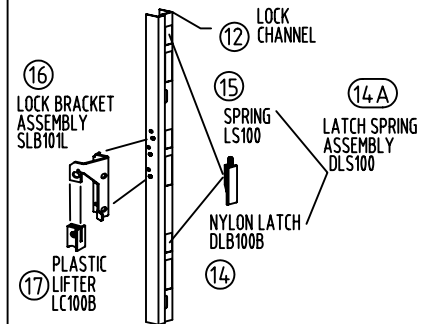

EXPLODED VIEW OF LOCK CHANNEL

OPTIONAL COAT ROD

BRACKETS TO BE BOLTED TO UNDERSIDE
OF HAT SHELF WITH COAT ROD IN BETWEEN.

xx ⑦ COAT ROD BRACKETS (xxTRH 200)
xx ⑧ COAT ROD (xxKCRww)

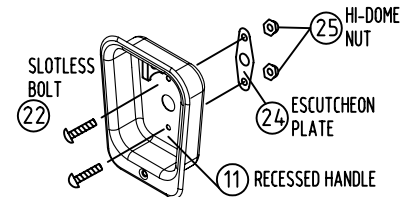
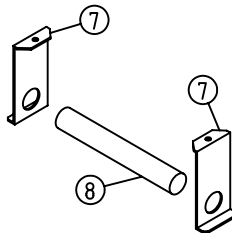

ASSEMBLY OF ESCUTCHEON PLATE

⑥ DOUBLE CEILING HOOK (H7K)

TO BE BOLTED TO
UNDERSIDE OF HAT SHELF.

⑤ SINGLE CEILING HOOK (H5K)

TO BE BOLTED TO
UNDERSIDE OF HAT SHELF.

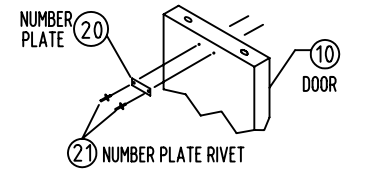

ASSEMBLY OF NUMBER PLATE