

# GALVANITE K. D. 6-TIER STOCK LOCKER ASSEMBLY INSTRUCTIONS

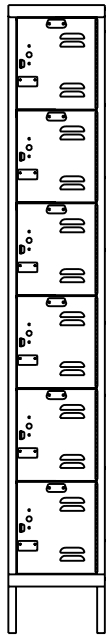

1-WIDE

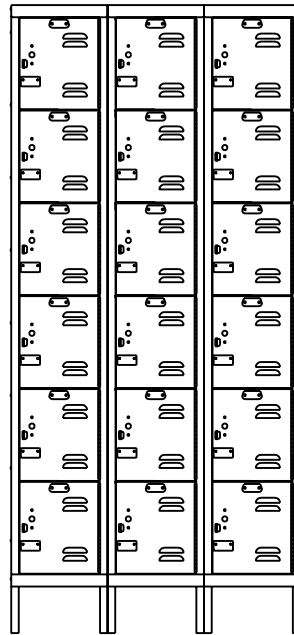

3-WIDE

## General Instructions

1. Check material received against the packing list. First check the number of packages received and then check the contents of each package.
2. Check material received for damage. If damage has occurred, secure a "damage notation" from the carrier.
3. Identify each part as it is unpacked and put like parts together as close as possible to the working area in which they are to be assembled.
4. Be careful to use the correct hardware as specified in the assembly instructions.
5. Items with suffix (xx) are available options.

## CAUTION

IN THE INTEREST OF SAFETY, ALL LOCKERS MUST BE SECURELY ANCHORED TO THE FLOOR AND/OR WALL.  
FOR SAFETY, HANDLE ALL COMPONENTS CAREFULLY AND WEAR WORK-GLOVES WHEN ASSEMBLING LOCKERS.

INSTALL ALL UNITS PLUMB AND TIGHTEN ALL HARDWARE SECURELY.

RETAIN INSTRUCTIONS FOR FUTURE REFERENCE.



401 Jim Moran Blvd., P.O. Box 9601  
Deerfield Beach, FL 33442

Phone (954) 429-9155  
Fax (954) 428-3843

[www.ListIndustries.com](http://www.ListIndustries.com)

# GALVANITE K.D. 6-TIER STOCK LOCKER ASSEMBLY INSTRUCTIONS

## PACKAGE CONTENTS

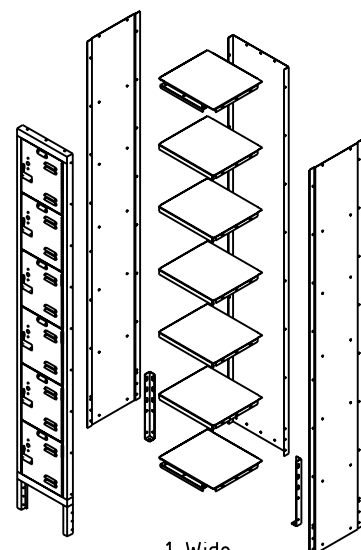
REF. NO.	DESCRIPTION	PART NO.	1-WIDE QUANTITY 6-TIER	3-WIDE QUANTITY 6-TIER	
①	REAR PANEL	KRww72G	1	3	 <p style="text-align: center;">1-Wide 6-Tier K.D. Locker</p>
②	RIGHT/LEFT SIDE PANEL	KPdd72G	2	4	
③	TOP/BOTTOM SHELF	KSwwddG	2	6	
④	INTERMEDIATE SHELF	KHwwddG	5	15	
⑤	DOOR FRAME ASSEMBLY	LKDFww78-6G	1	3	
x ⑥	DOOR	LKDww72-6LV-G	6	18	
⑦	BOX DOOR LATCH PULL	KBLP100	6	18	
⑧	NUMBER PLATE	NPL	6	18	
⑨	NUMBER PLATE RIVET	RV101	12	36	
xx ⑩	STRIKE PLATE	xxSP100	xx6	xx18	
⑪	REAR LEG	KLG	2	2	
⑫	3/8" SLOTLESS BOLT	MBT200	94	282	
⑬	HEX NUT	N201	82	246	
⑭	HI-DOME CAP NUT	N110	12	36	
x ⑮	PIANO HINGE	PH11	6	12	
x ⑯	RIVET (HINGE)	RV102	12	36	

PART NUMBER SUFFIX SHOW WIDTH, HEIGHT, DEPTH AND TIER CUSTOMER TO SPECIFY.

### NOTE:

FOR OPTIONAL INDIVIDUAL SLOPE TOPS,  
SEE SUPPLEMENTAL INSTRUCTION SHEET NO. ASY-L-KIST-A

FOR OPTIONAL 6" HIGH CLOSED METAL BASE,  
SEE SUPPLEMENTAL INSTRUCTION SHEET NO. ASY-L-KIST-B

x SHIPS PRE-HUNG IN DOOR FRAME ASSEMBLY.  
xx STRIKE PLATES ARE OPTIONAL - INCLUDES TWO RIVETS ⑨.

### PART NO. LEGEND:

dd = DEPTH  
ww = WIDTH

**TOOLS REQUIRED: 3/8" NUT DRIVER (3/8" SOCKET MAY BE SUBSTITUTED)**

## TWO-YEAR WARRANTY

LIST INDUSTRIES KD LOCKERS ARE COVERED AGAINST ALL DEFECTS IN MATERIALS AND WORKMANSHIP EXCLUDING FINISH, DAMAGE RESULTING FROM DELIBERATE DESTRUCTION AND VANDALISM UNDER THIS SECTION FOR A PERIOD OF TWO YEARS.



# GALVANITE K.D. 6-TIER STOCK LOCKER ASSEMBLY INSTRUCTIONS

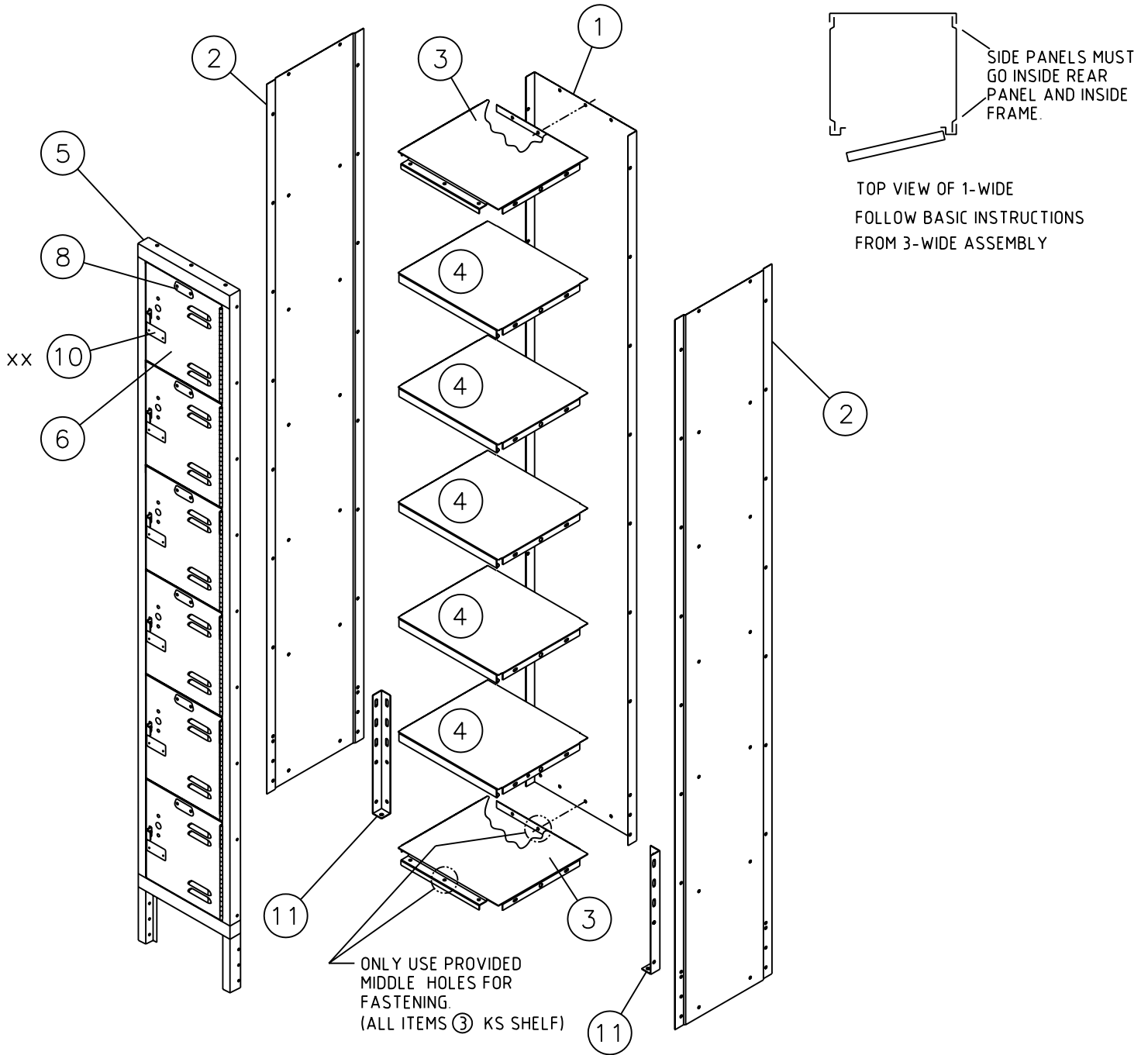

LIST INDUSTRIES MAKES EVERY EFFORT TO ENSURE THAT ALL UNITS SHIP COMPLETE. HOWEVER, SHOULD YOUR UNIT CONTAIN MISSING OR DAMAGED PARTS, REPLACEMENTS MAY BE OBTAINED FROM LIST INDUSTRIES. TO OBTAIN PARTS, FOLLOW THESE INSTRUCTIONS.

## PLEASE PROVIDE THE FOLLOW INFORMATION:

MODEL NUMBER

PURCHASE DATE

DESCRIPTION OF PART(S) NEEDED & PART NUMBER(S) AS SHOWN IN PARTS LIST  
COLOR

COMPANY NAME & CONTACT PERSON

WHERE THE PRODUCT WAS PURCHASED FROM

IF REQUESTING PARTS BY TELEPHONE, ASK FOR CUSTOMER SERVICE & PROVIDE THE ABOVE INFORMATION.



# GALVANITE K.D. 6-TIER STOCK LOCKER ASSEMBLY INSTRUCTIONS

(A GROUPING OF (3) THREE 6-TIER LOCKERS ILLUSTRATED )

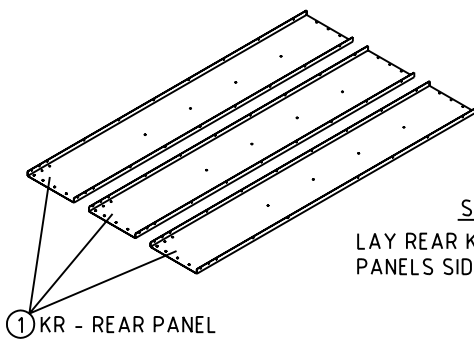

**STEP 1**  
LAY REAR KR ①  
PANELS SIDE BY SIDE.

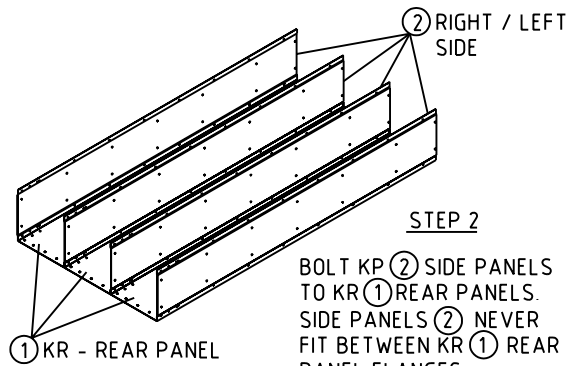

**STEP 2**  
BOLT KP ② SIDE PANELS  
TO KR ① REAR PANELS.  
SIDE PANELS ② NEVER  
FIT BETWEEN KR ① REAR  
PANEL FLANGES.

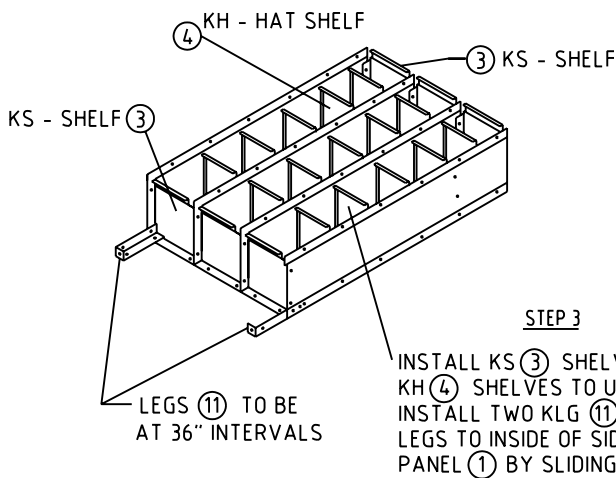

**STEP 3**  
INSTALL KS ③ SHELVES AND  
KH ④ SHELVES TO UNIT.  
INSTALL TWO KLG ⑪ REAR  
LEGS TO INSIDE OF SIDE ②  
AND REAR  
PANEL ① BY SLIDING INTO PLACE FROM BOTTOM.

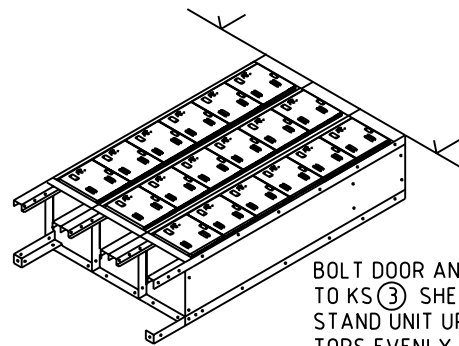

**STEP 4**  
BOLT DOOR AND FRAME ⑤ ASSEMBLIES  
TO KS ③ SHELVES AND KP ② SIDE PANELS.  
STAND UNIT UP AND ALIGN LOCKER  
TOPS EVENLY. TIGHTEN ALL BOLTS  
AND NUTS.  
NOTE: WHEN BOLTING ONE UNIT TO  
ANOTHER, OMIT ONE SET OF BOLTS  
IN END FRAME AND SIDE TO MINIMIZE  
GROWTH FROM BOLT HEADS.

## ASSEMBLY OF SINGLE ROW LOCKERS NEVER PUT SIDE PANELS BETWEEN FRAMES.

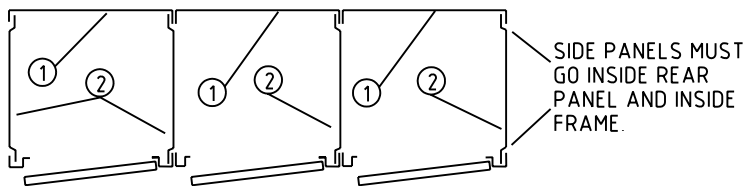

3-WIDE UNIT PLAN VIEW

SIDE PANELS MUST  
GO INSIDE REAR  
PANEL AND INSIDE  
FRAME.

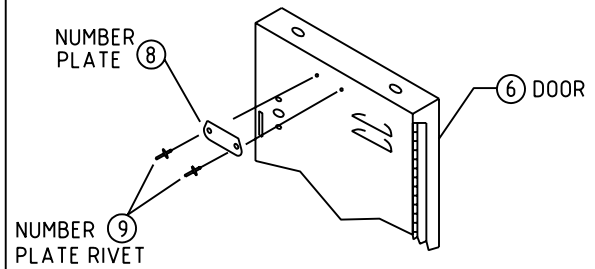

ASSEMBLY OF NUMBER PLATE

## HARDWARE USED FOR MAIN LOCKER ASSEMBLY



10 - 24 x 3/8"

MBT200 SLOTLESS BOLT ⑫



N201 HEX NUT ⑬

TIGHTEN NUT WITH A NUT DRIVER OR WRENCH  
(SCREW IS TAMPER RESISTANT).

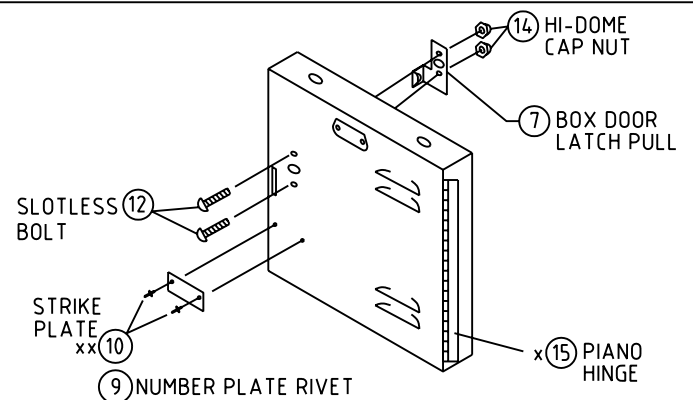

ASSEMBLY OF STRIKE PLATE & LATCH PULL

